

NM Southeast District 4-H Contest

Family and Consumer Sciences
Skill-a-thon

Sewing & Clothing Identification Items
Photos & Definitions

Revised May 2021

Sewing
And
Clothing ID

Fabric/Etc.

Cotton



- Good material for first time sewers to use. Has a good hand and little elasticity. Considered a heavy weight material. Used for everyday clothing.

Fleece



- Fabric with a soft deep pile. Mostly made up of 100% polyester (synthetic) fibers but at times may also contain other fibers like cotton, spandex, or rayon. It is a soft warm fabric and often used when making winter clothes and blankets. It is a knit fabric rather than woven and does not fray at the cut edges.

Selvage

The selvage edge is the woven edge that does not fray

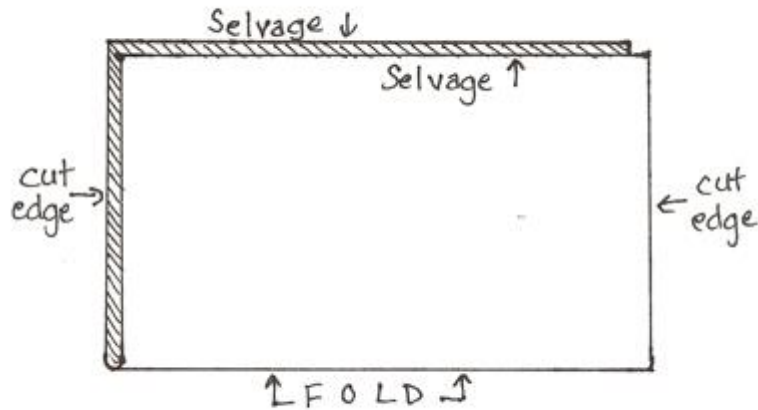

Fabric has two selvage edges and two cut edges



- Uncut edge on both the right and left side of fabric as it is woven. The way it is finished makes it unsuitable for fabrication.

Wool



- A fabric made from wool fibers. Wool fibers are derived from the fleece of sheep and other animals. Fabric ranges from soft, fuzzy or smooth textured, heavy or lightweight, and warm. Commonly used for sweaters, socks, suits, pants, gloves, and other forms of cold-weather gear.

Sewing
And
Clothing ID

Sewing Machine Parts

#6 – Balance/Hand Wheel

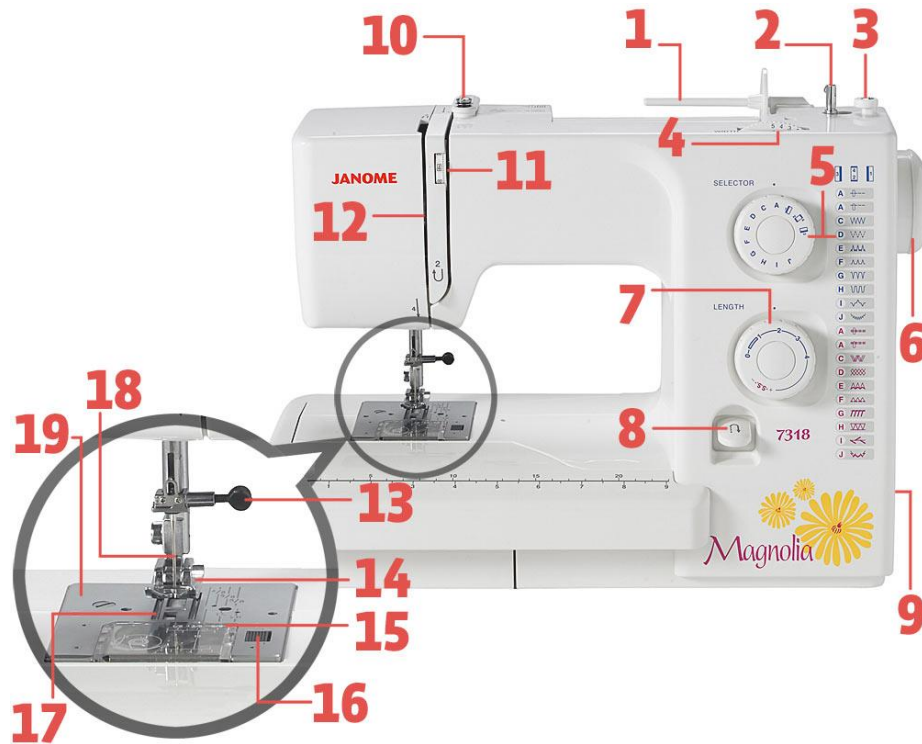

- The balance or hand wheel is used when you want to manually move the needle up and down. The hand wheel can be pulled out when you want to disengage the needle (run the spool of thread without the needle going up and down). The hand wheel raised and lowers the needle. You must always pull the hand wheel towards yourself to prevent tangling of the threads.

Bobbin



- Cylinder on which thread is wound for sewing. Holds the bottom thread.

Bobbin Case

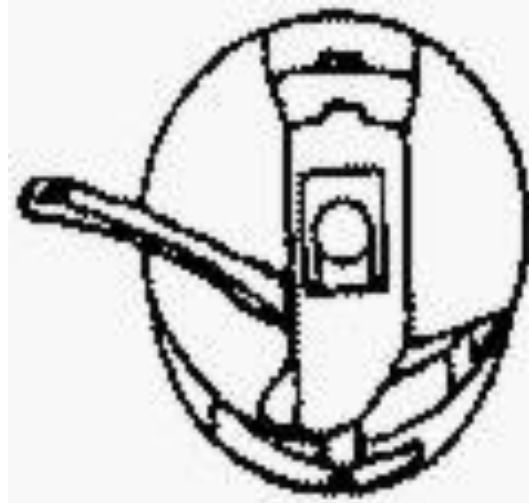

- Holds the bobbin.

#16 - Bobbin Winder

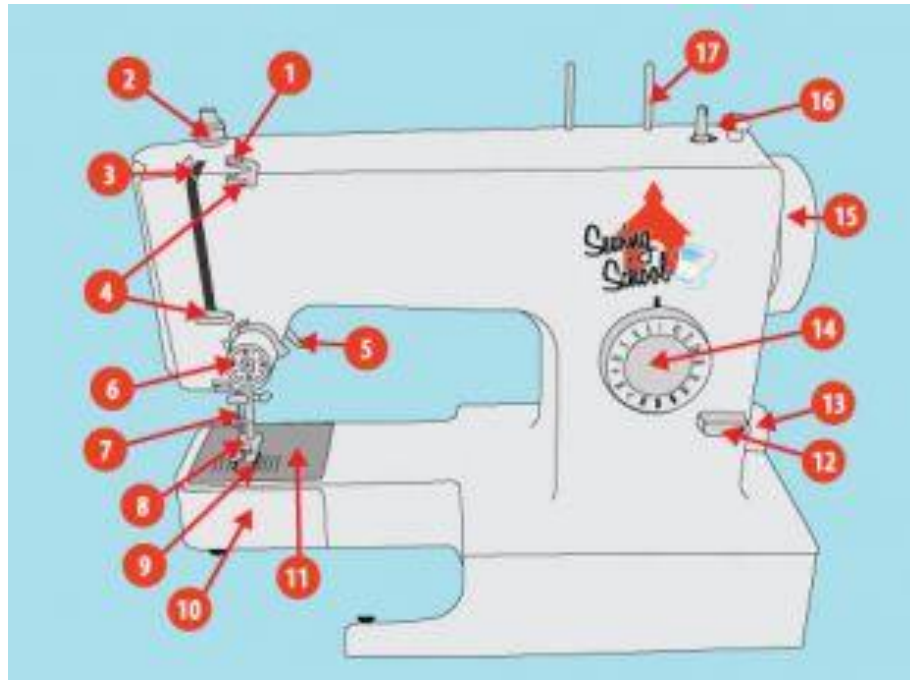

- Holds the bobbin in place when winding tread onto the bobbin. It is usually a shorter pin located next to the spool pin on sewing machines.

#17 – Feed Dogs

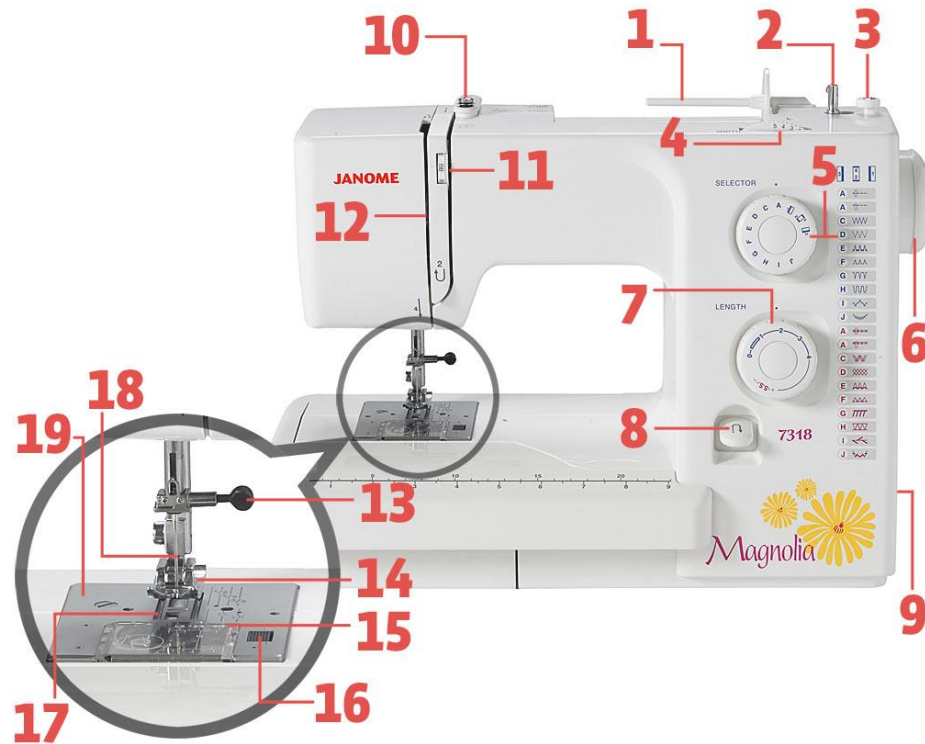

#17

- It is the part under the needle plate where the teeth are used to move it forward. It is the feeder mechanism which is typically used to pull fabric through a sewing mechanism.

#38 - Foot Control

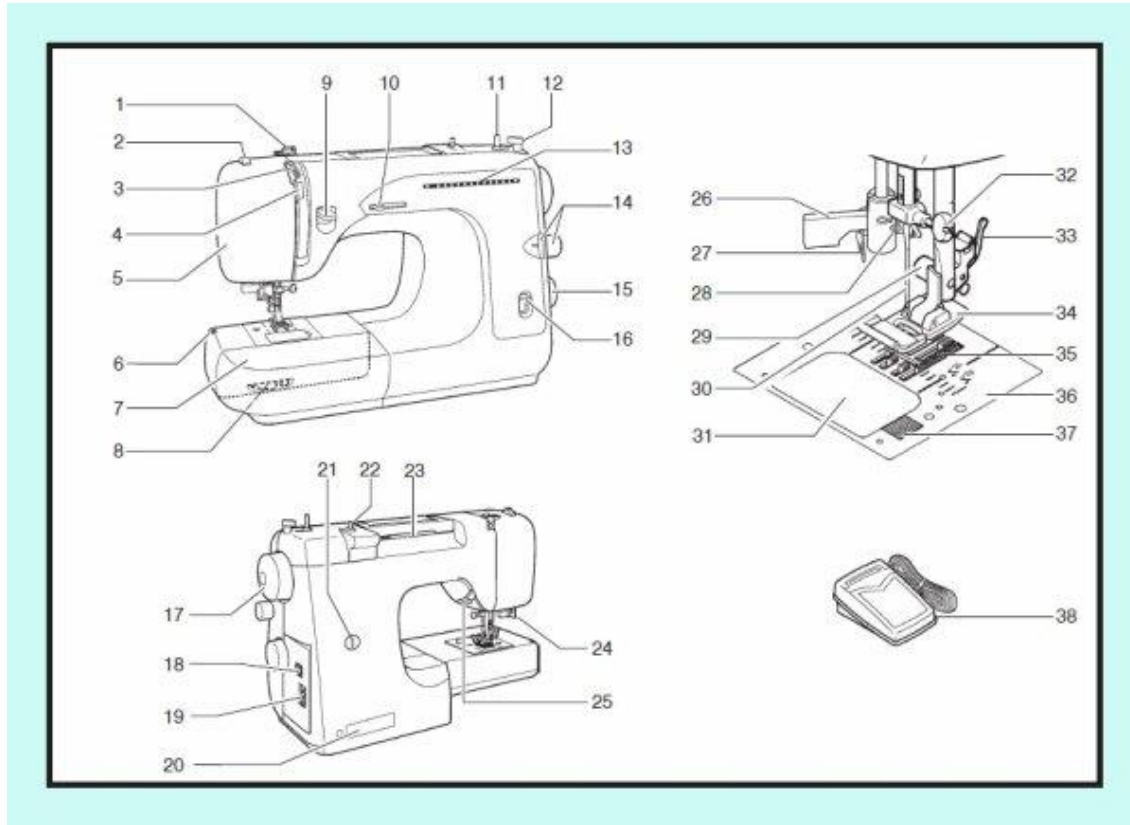

- A device which is placed on the floor rather than the table, which is stepped on. Used to apply power to the sewing machine or serger.

#34 – Presser Foot

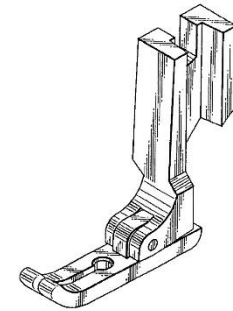
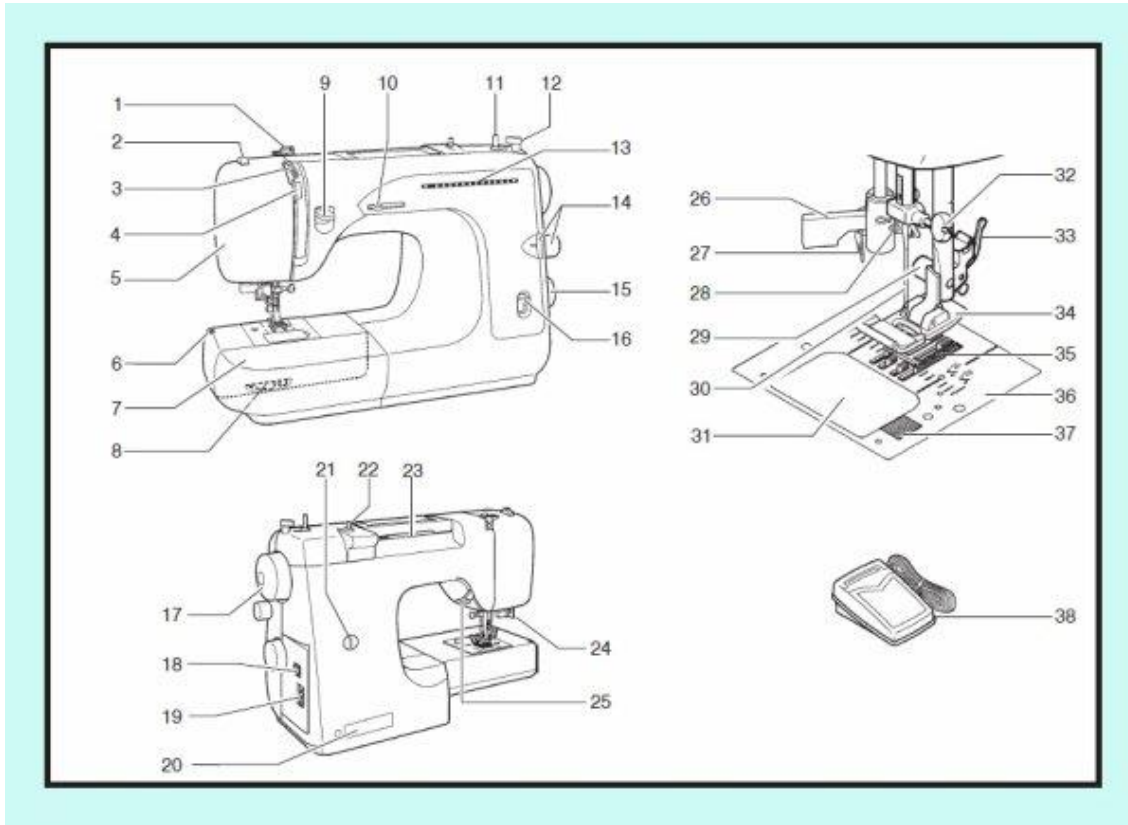

#34

- The presser foot holds the fabric in place during sewing. The presser foot must be lowered before you begin to sew or fabric will not move through the machine.

#5 Presser Foot Lifter

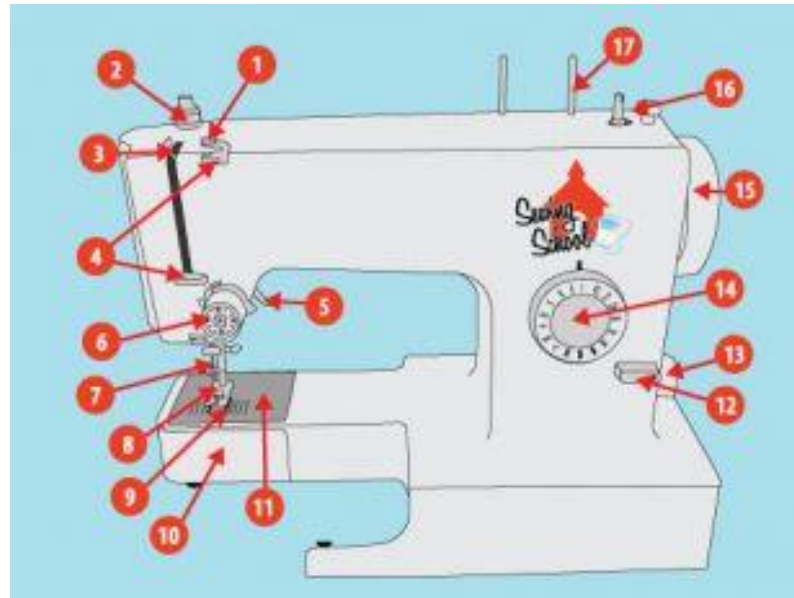

- The presser foot is used to hold the fabric down to the needle plate so it can be sewn smoothly. When you sew, the presser foot should be down; when you're done sewing, lift it up with the presser foot lifter.

#1 - Power Switch



- Turns the sewing machine on or off. Often found on the side of the sewing machine, next to the power cord.

#30 – Sewing Machine Needle

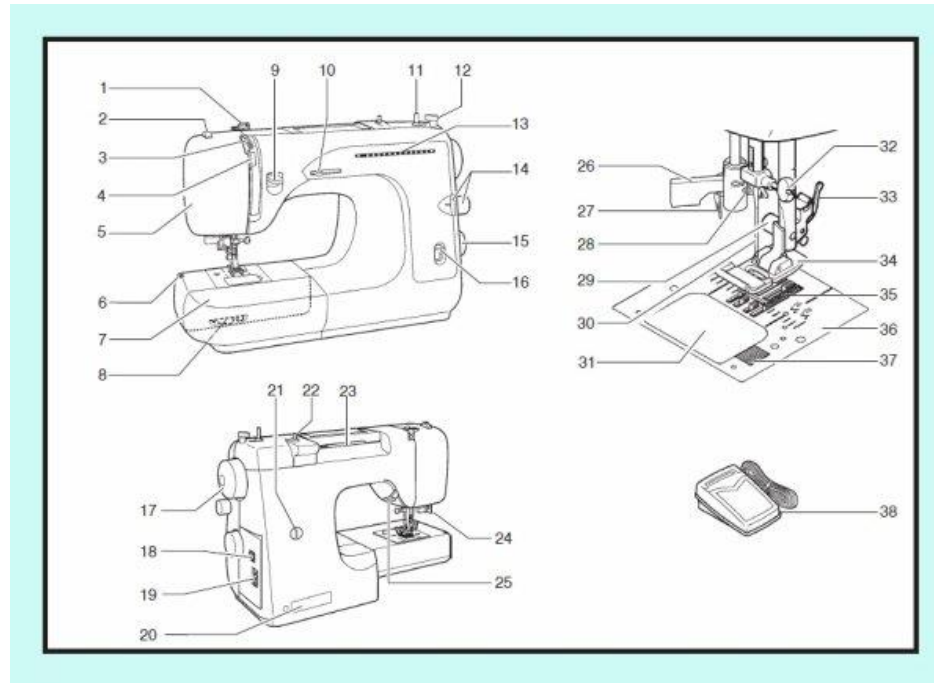

- A sewing machine needle consists of: a shank - clamped by the sewing machine's needle holder; shoulder - where the thick shank tapers down to the shaft; shaft - a length suitable for driving the eye and thread through the material and down to the bobbin; groove - cut in the back of the shaft to release the thread into a loop that aids the hook or shuttle to pick up the thread; scarf - provides extra room for the hook or shuttle to pass close by; eye - carries the thread; and point - penetrates the material by parting the threads or cutting a hole.

#17 – Spool Pin

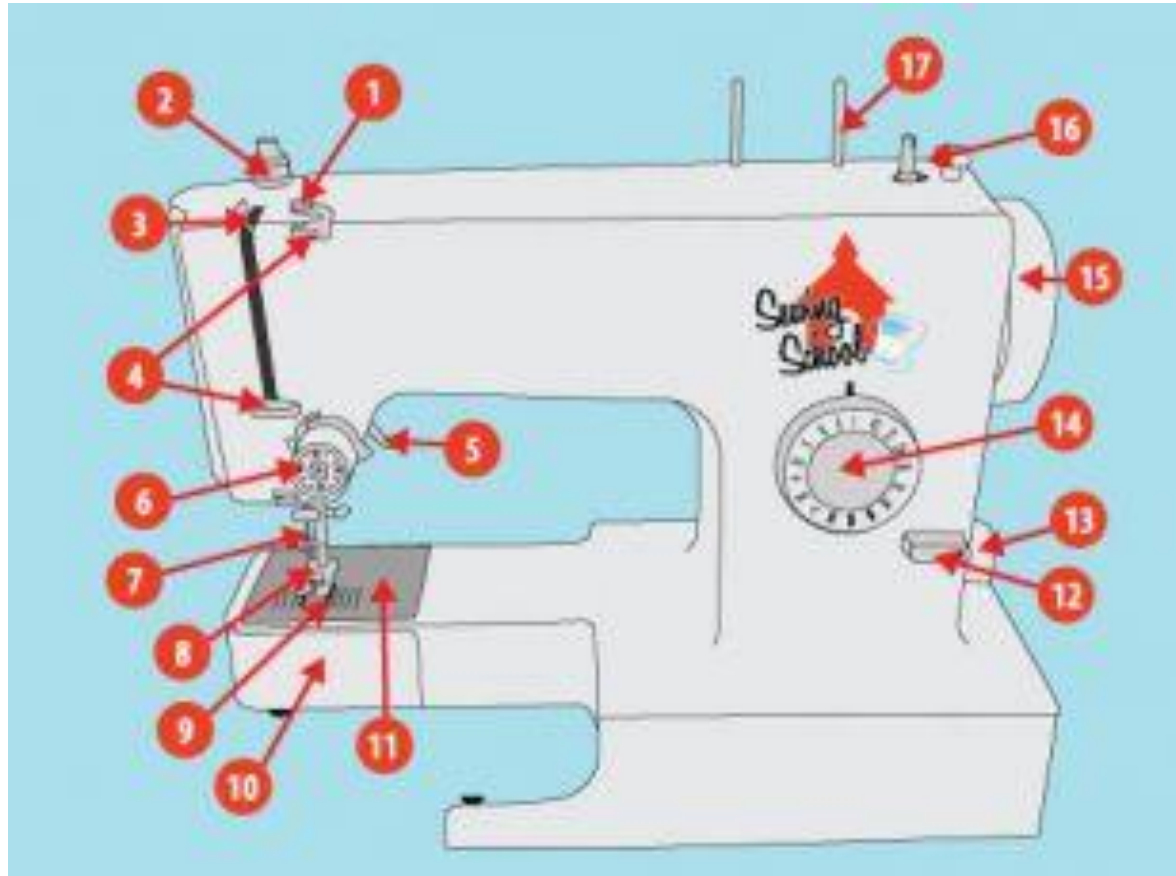

- Holds the spool of thread. Sewing machines may have a vertical spool pin or a horizontal spool pin.

#3 – Thread Take Up

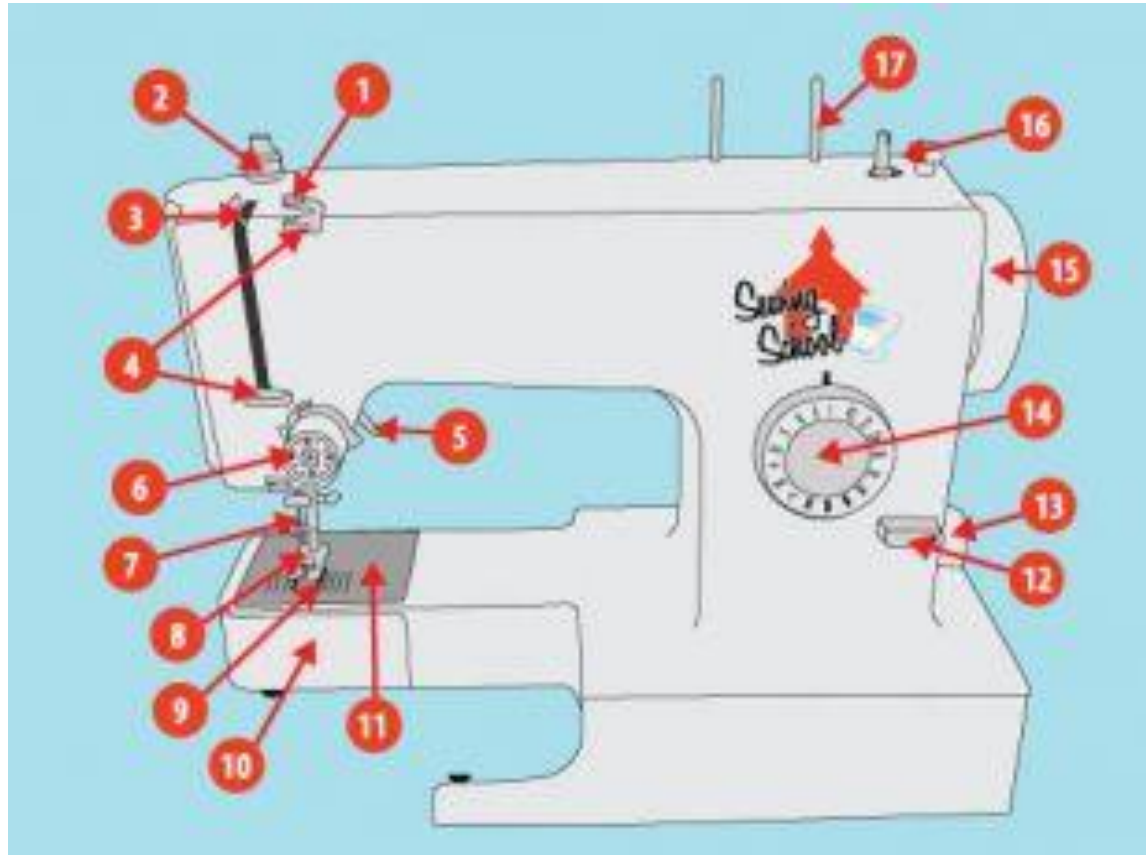

- The take up lever is used in threading the sewing machine and to keep the thread tension at the proper level. If the take up lever is threaded improperly, the thread will knot up and jam in the machine.

#11 – Throat Plate

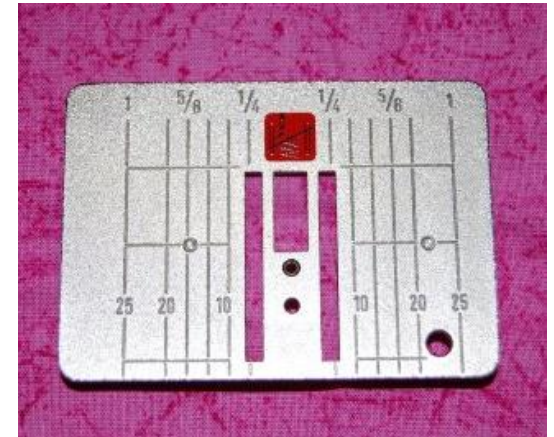
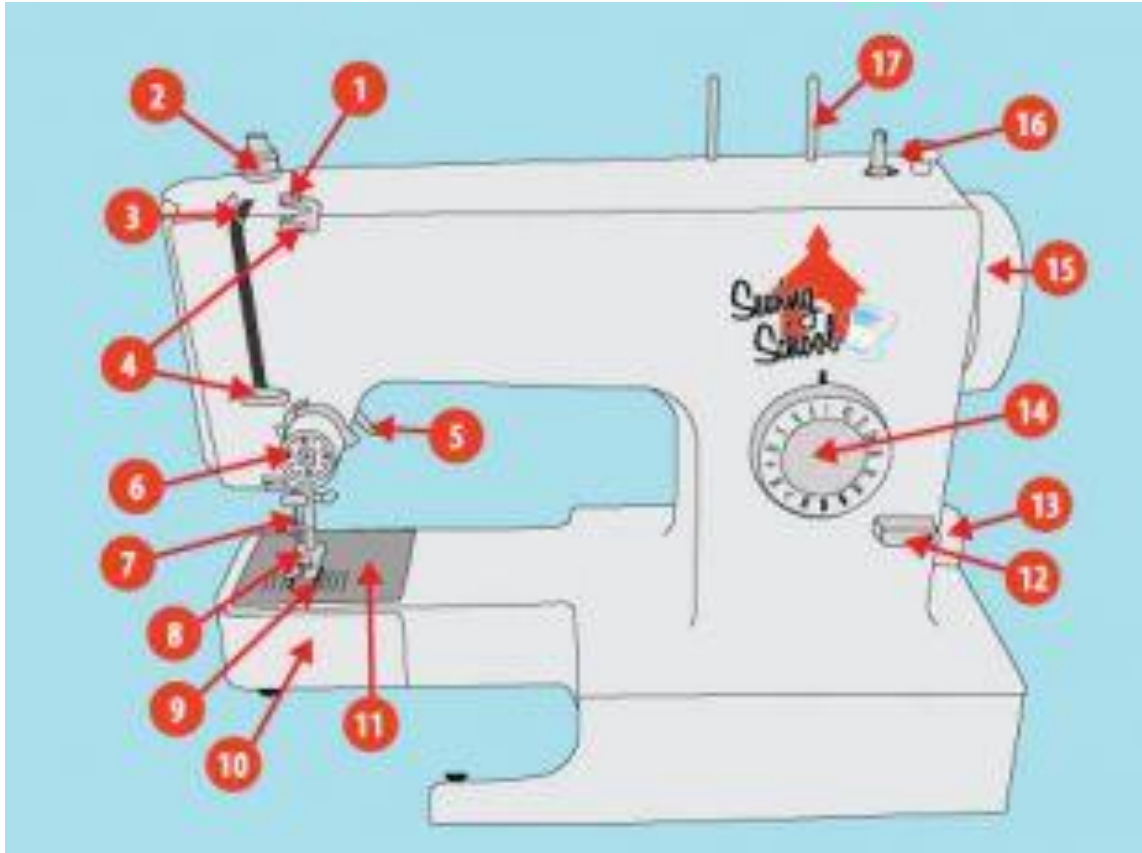

#11

- The throat plate is a metal plate with openings for the needle and or the feed dogs .

#6 – Upper Tension Regulator

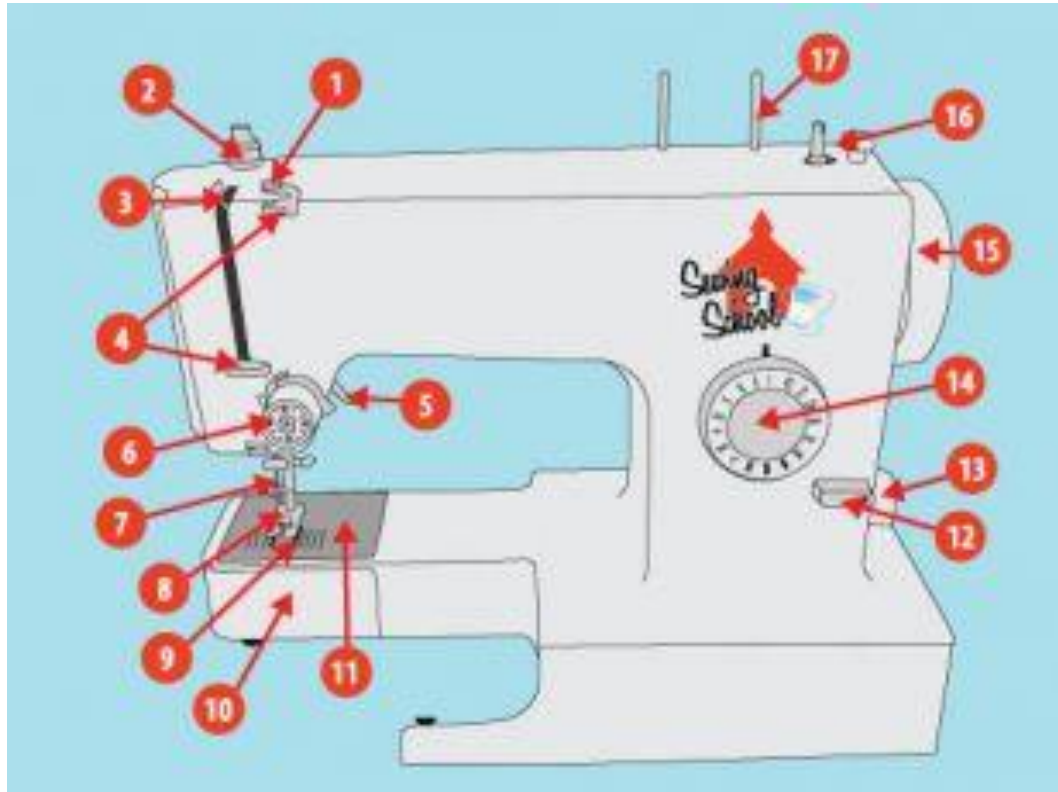

- A sewing machine feature (dial) that sets the balance between the bobbin and needle threads. On some sewing machines the tension has one permanent setting. On other machines the tension can be set or is adjusted automatically according to the type of fabric.

Sewing
And
Clothing ID

Techniques

Applique



- To attach a small piece of fabric to a larger piece of fabric, to create a desired design.

Center Zipper Application



- A type of zipper insertion in which the zipper teeth are centered between the fabric opening. In this type of zipper application, the fabric covers the zipper equally on both sides, meeting the middle of the opening, and the stitching is visible on either side of the zipper opening.

Dart

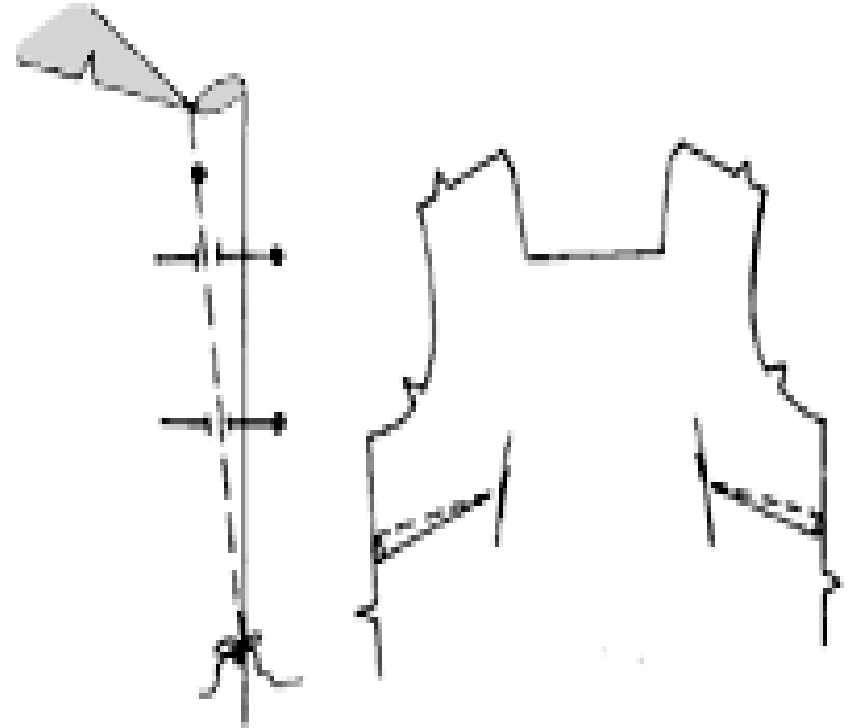
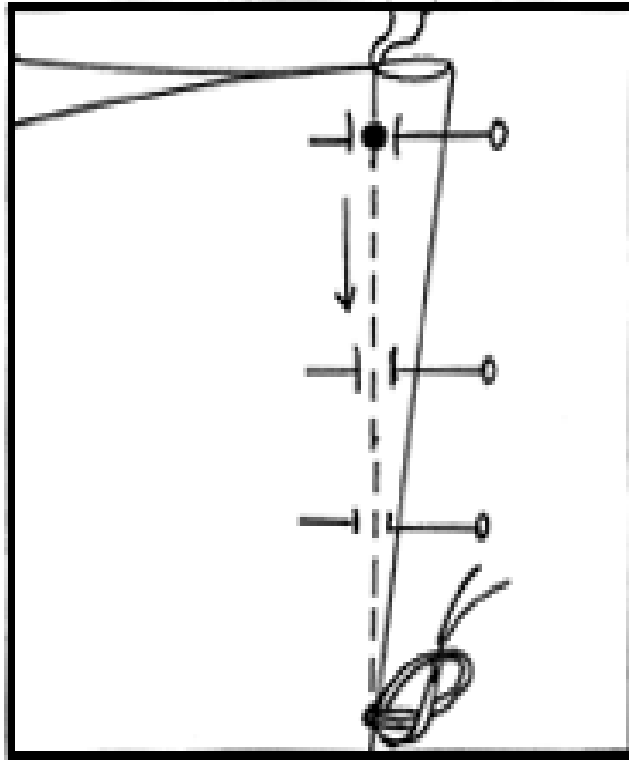

- A tapered tuck sewn to adjust the fit of a garment.

Gather

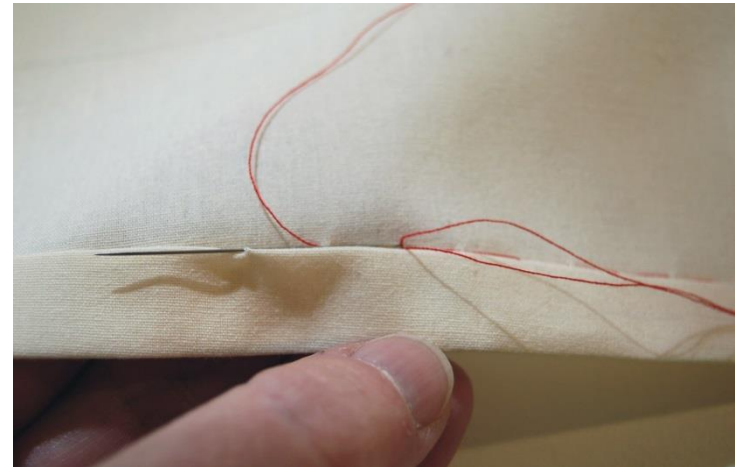
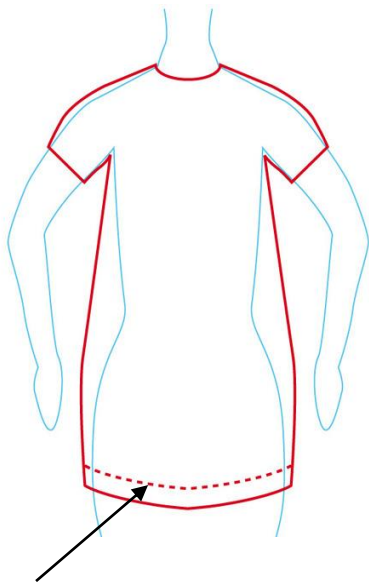

Fig. 18.—Showing full of the gathers bound and stitched.



- To draw into small folds or puckers, as by pulling a thread through cloth.

Hem



- An edge or border on a piece of cloth, especially a finished edge, as for a garment or curtain, made by folding an edge under and stitching it down.

Pleat



- A fold in cloth made by doubling the material upon itself and then pressing or stitching it into place.

#1 - Seam Allowance

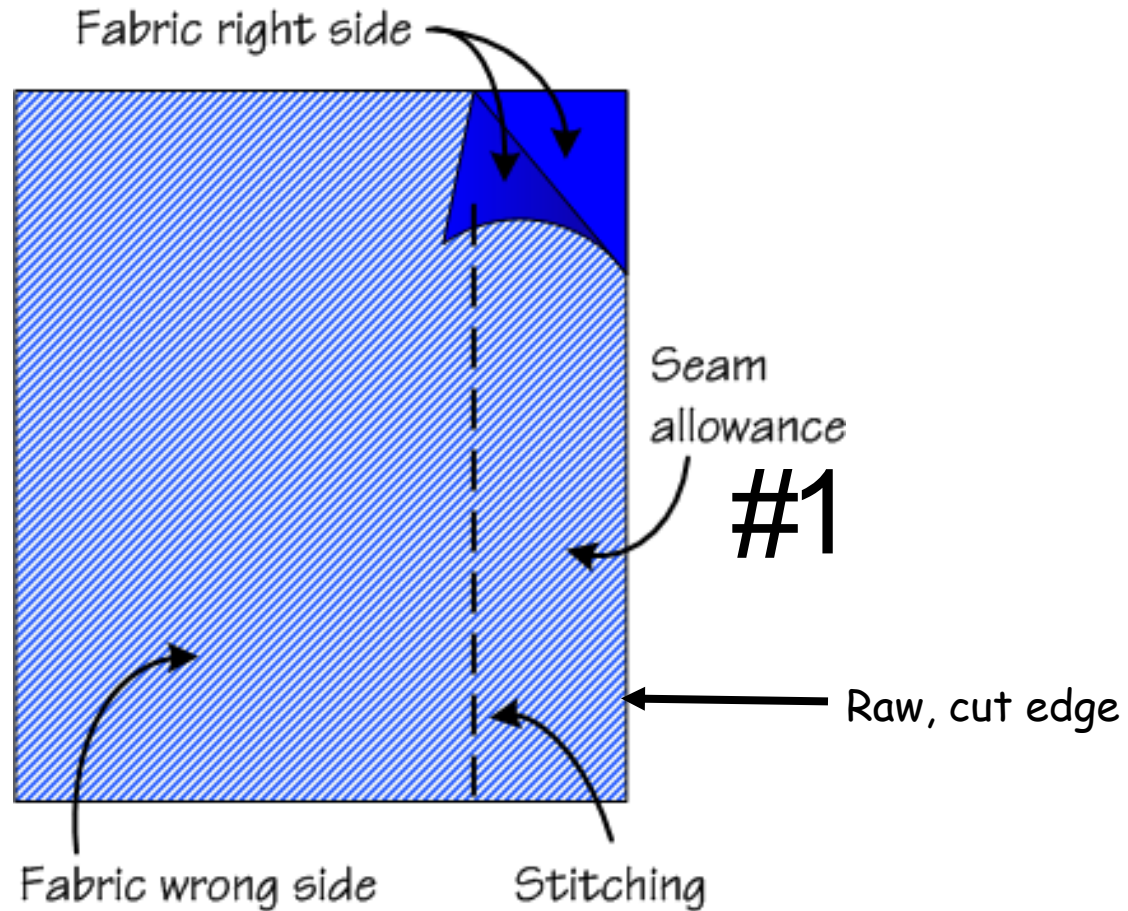

- The area between the stitching and raw, cut edge of the fabric.

Sewing
And
Clothing ID

Trims & Fasteners

Batting



- Cotton, wool, or synthetic fiber wadded into rolls or sheets, used for stuffing furniture and mattresses and for lining quilts.

Bias Tape



- Narrow strip of cloth that is cut on the bias (diagonal to the grain of the fabric) that can be used to finish or decorate clothing.

Button



- A generally disk-shaped fastener used to join two parts of a garment by fitting through a buttonhole or loop.

Decorative Trim



- A wide range of items used to embellish a sewing project. Can include lace, fringe, beads, braids, ribbon, cording, piping, pom poms and more. Decorative trims are accents that add an extra finishing touch to sewing.

Elastic



- A flexible stretchable fabric made with interwoven strands of rubber or an imitative synthetic fiber.

Hooks and Eyes



- Clothes fasteners consisting of a small hook and metal loop. Used as closures at the tops of shirts, skirts, dresses or pants.

Ribbed Elastic



- Provides maximum cross strength. Found in pants and shorts.

Sew On Snaps



- Used as closures at the tops of garments.

Sewing
And
Clothing ID

Tools

Acrylic Ruler

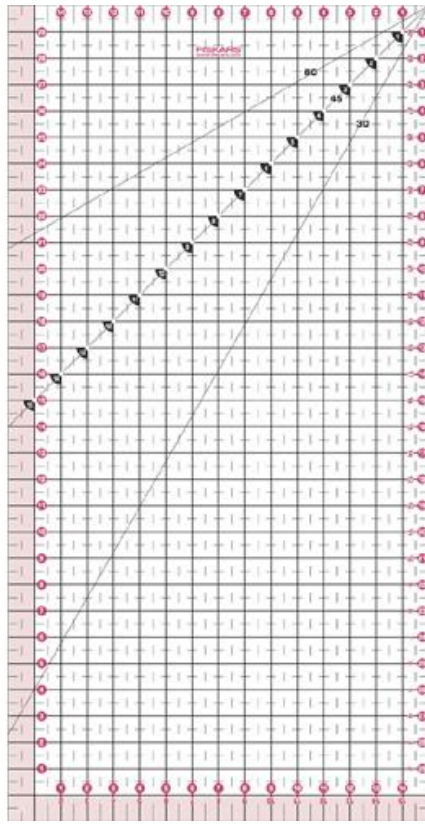
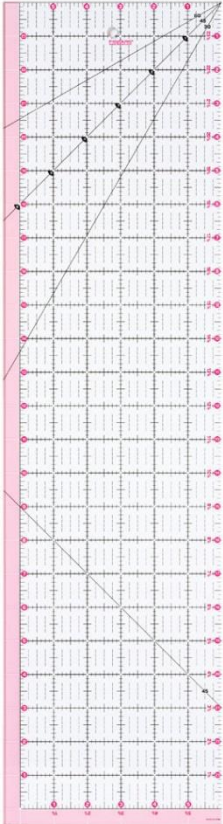

- Ruler used in crafts and clothing showing different measurement. May come in different shapes and sizes.

Ball Point Bodkin



- Features a ball point end. On the opposite end of the ball point, it has a blunt needle with a large eye for drawing elastic or ribbon into a casing.

Crewels



- Needles with long eyes for easy threading.

Cutting Mat

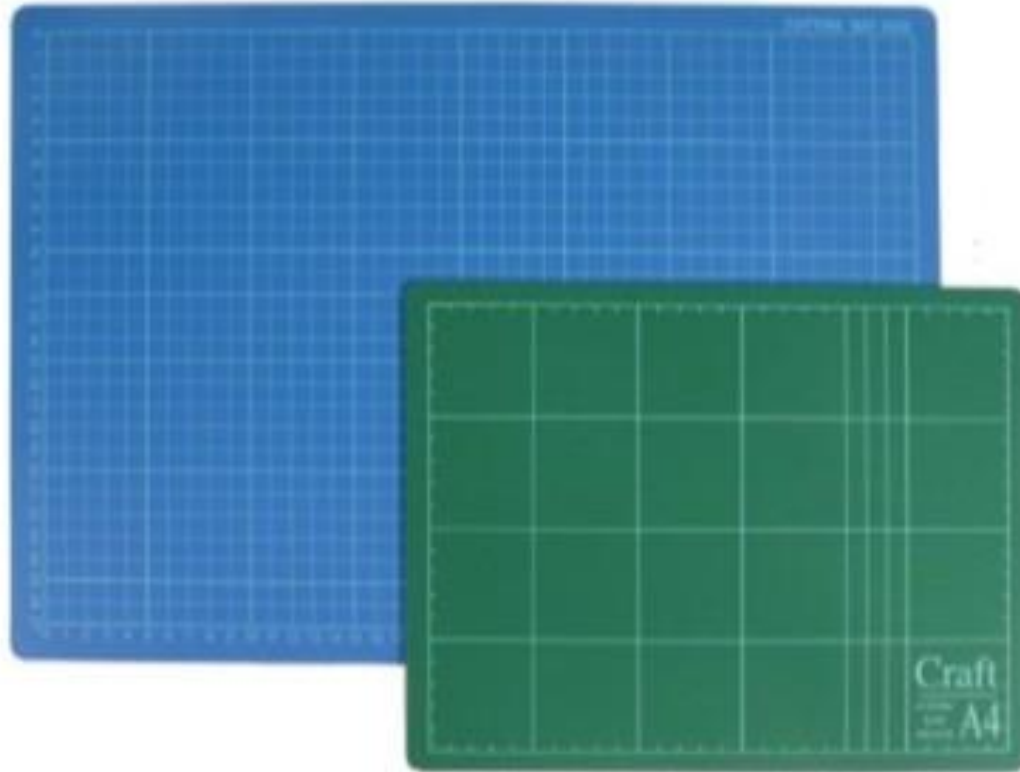

- Mat that is placed down to protect the table surface while cutting.

Dressmakers Ham



- Used for ironing on hard to reach areas.

Emery Bag

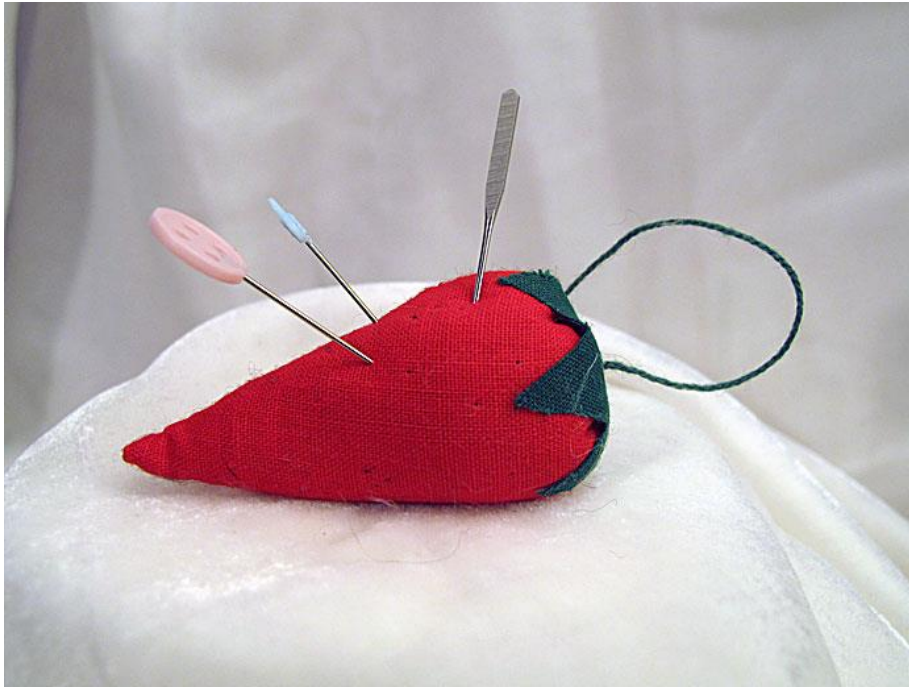

- A small bag into which a needle or pin can be jabbed into. It is used to sharpen needles or pins.

Iron



- A metal appliance with a handle and a weighted flat bottom, used when heated to press wrinkles from fabric.

Ironing Board



- A long, narrow padded board, often with collapsible supporting legs, used as a working surface for ironing.

Loop Turner



- A tool used for turning bias tubing, button loops, purse straps, and more. The long wire with the hook end is inserted into one end of a sewn tube, latched onto the fabric using the hook at the other end, then pulled all the way through the tube, turning it right side out in the process.

Measuring Tape



- Used for measuring larger pieces of fabric and body measurements.

Needle Threader



- Used to thread machine or hand needles.

Pin Cushion

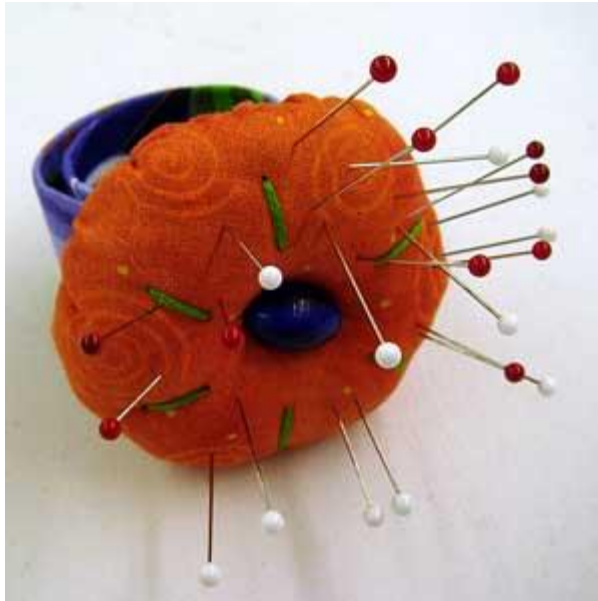

- A small cushion used for holding pins for easy access.

Pinking Shears



- Used for finishing seams.

Pins

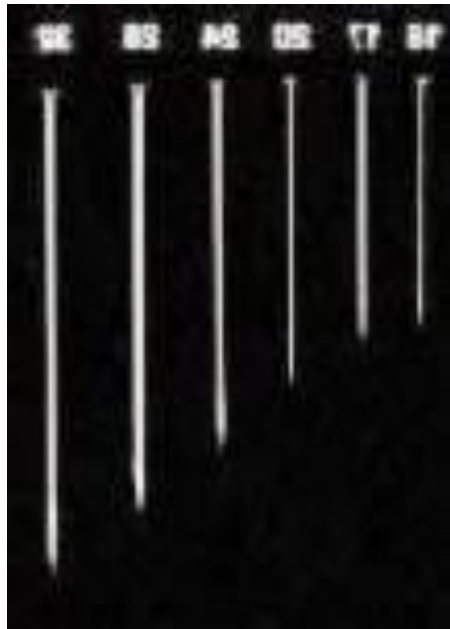

- Used for holding material together while sewing. Come in two forms: dressmaker or silk pins are fine and sharp and are the best to use.

Rotary Cutter



- A wheel with a sharp edge that is used to cut fabric, used on a cutting mat.

Safety Pins



- A loop shaped pin that fastens into itself with its points under a protective cover to prevent accidental opening or injury.

Scissors



- Used for cutting paper and clipping fabric. Scissors may have a straight handle.

Seam Ripper



- Used to take out seams as well as making buttonholes.

Sewing Gauge



- A short ruler that has a moveable slide for marking hems, seams, and other areas.

Sharps

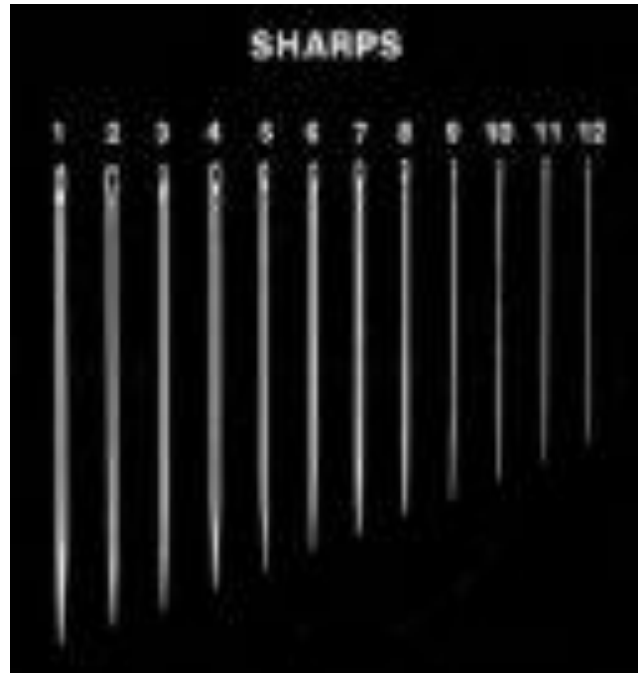

- Needles with small round eyes.

Shears



- Used for cutting fabric, not paper. Shears are 7-8 inches long, are sharp, and have bent handles making them easier to cut with.

Tailors Chalk

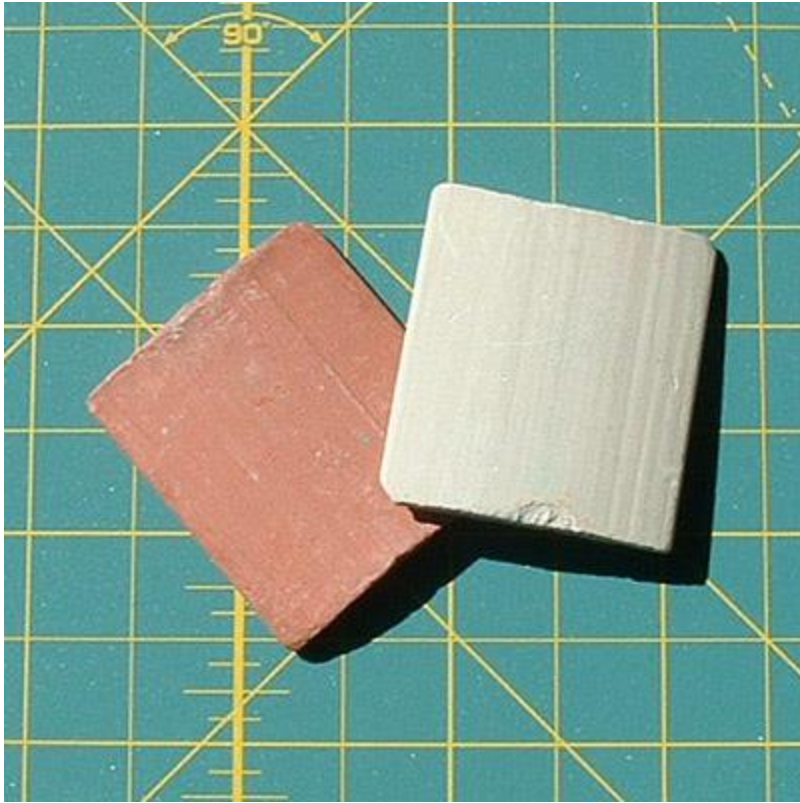

- Used for marking sewing details on fabric.

Thimble

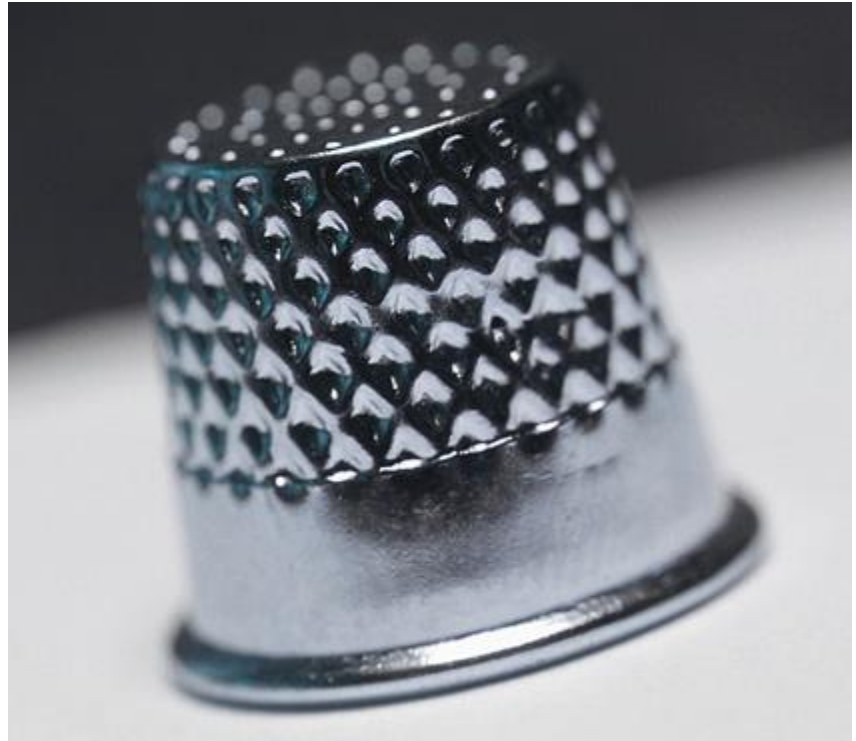

- Used to protect your fingers when hand sewing.

Thread



- Fine cord of fibrous material, such as cotton or flax, made of two or more filaments twisted together and used in needlework and the weaving of cloth.

Tracing Paper



- Paper used to mark sewing details on fabric.

Tracing Wheel

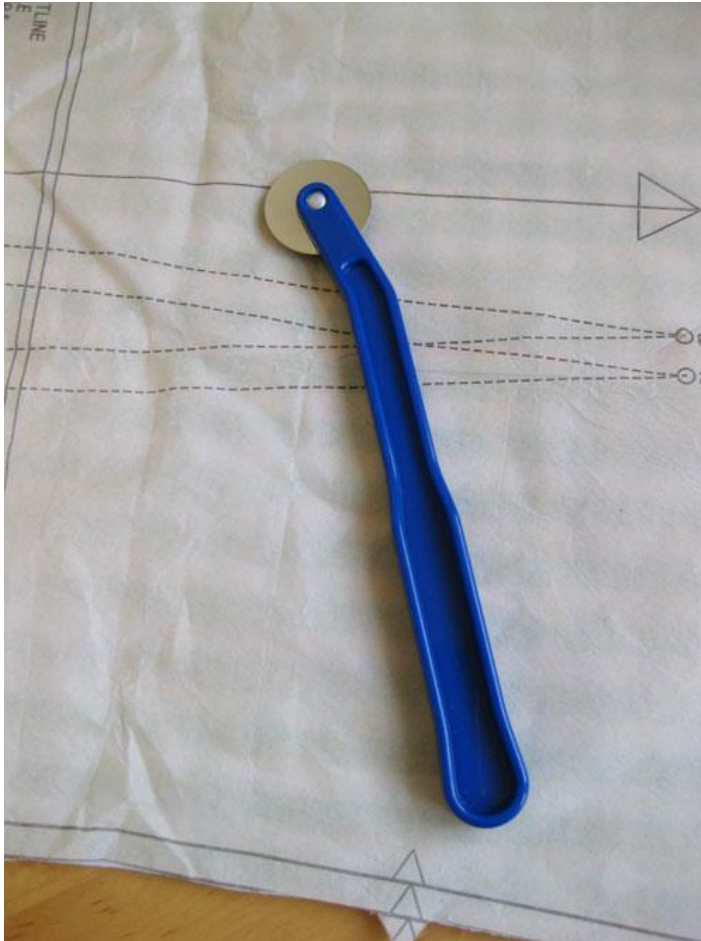

- Wheel used along with tracing paper to transfer sewing details to fabric.